

ETHOS UP/ETHOS EASY **ACCESSORIES LINE**

MMR-15

MICROWAVE MODULAR ROTOR



MILESTONE
HELPING
CHEMISTS



Milestone ETHOS UP

The newly designed ETHOS UP and ETHOS EASY fully embody Milestone's philosophy in microwave sample preparation.

They encompass Milestone's visionary concept of "Total Microwave Sample Preparation" and, with a comprehensive choice of accessories, they offer a complete first-class solution also for sample drying, vacuum evaporation, solvent extraction, protein hydrolysis, and alkaline fusion.

"The removal or reduction of the quantity of the hydrochloric and hydrofluoric acids prior to analysis may be desirable. Evaporation to near dryness in a controlled environment with controlled pure gas and neutralizing and collection of exhaust interactions is an alternative where appropriate. This manipulation may be performed in the microwave system, if the system is capable of this function..."

US EPA method 3052

The US patent 5,447,077 attested the pioneer work of Milestone in the investigation of the unique heating mechanism of microwave-assisted evaporation process.

The new MMR-15 rotor takes advantage of this technology and it is now available to chemists to improve the quality of the analytical results and to reduce the overall sample preparation time.

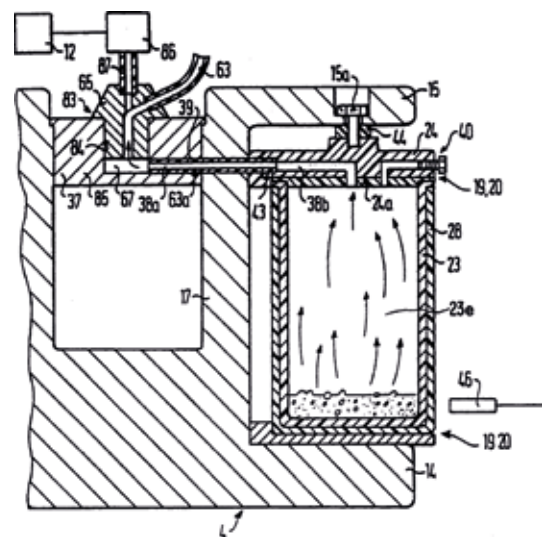

Extract from US patent 5,447,077

MMR TECHNOLOGY

Most US EPA microwave acid digestion methods (3015, 3051 and 3052) prescribe the use of combinations of HNO₃, HF and HCl.

HNO₃ is typically required as oxidizing acid, HF is used for silicates and HCl is recommended for soils and sediments. Solutions obtained by closed vessel digestion must often be evaporated prior analysis either to concentrate the elements of interest or to eliminate compounds which may interfere with the analytical technique being used.

A typical setup for microwave-assisted evaporation consists of the ETHOS UP or ETHOS EASY equipped with the VAC-1000 vacuum scrubber and the MMR-15 rotor.

The MMR-15 can be used for vacuum-assisted sample drying prior digestion, and solution concentration at the end of the decomposition process.

The MMR-15 accommodates up to 15 TFM vessels of 100 mL.

They are the same vessels used in the SK-15 digestion rotor, so no transfer of the solution is required when performing drying and concentration. This minimizes the risk of contamination or loss of the analytes of interest.

Each vessel fits snugly into an adapter which perfectly seals the system.

An adjustable valve with in-line filter regulates vacuum and air flow.

All surfaces in contact with the solution are made of high-purity TFM.

Sample are therefore processed in a clean, inert environment.

The VAC-1000 integrates a vacuum pump, a water cooled condenser and a neutralizing module to properly and safely handling acid vapors; it is the perfect complement to the MMR-15 rotor.

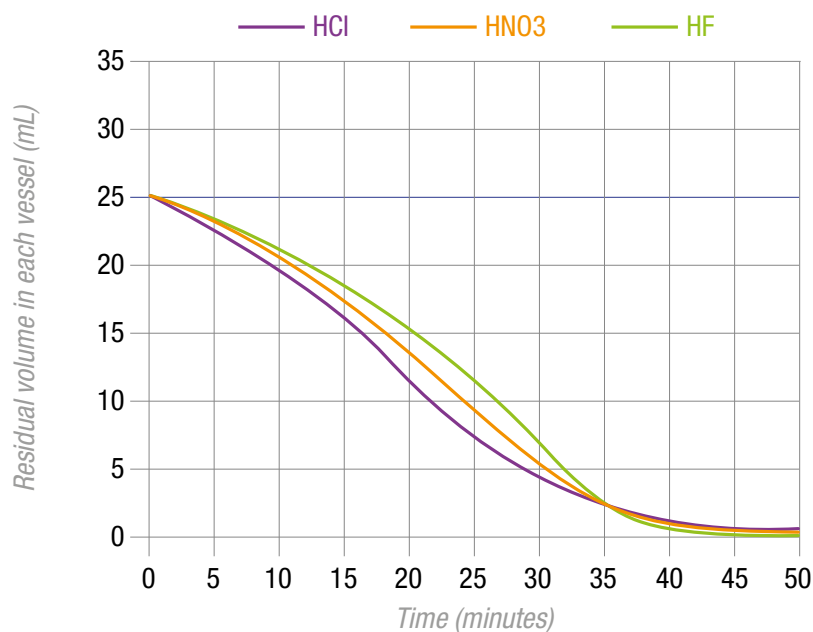

Evaporation time for HCl, HNO₃ and HF

MMR CHEMISTRY

The paper “Use of Microwave-Assisted Evaporation for the Complete Recovery of Volatile Species of Inorganic Trace Analysis”, written by Skip Kingston and Dirk Link, and published in Analytical Chemistry some years ago, did compare the heating mechanism of hot plate and microwave assisted evaporation. It was demonstrated that -when using microwave, elements loss by volatilization is minimized, because the temperature of the solution decreases as volume decreases during the evaporation process. Subsequent re-dissolution and analysis of the residue by ICP-MS showed that a complete recovery was achieved when using microwave-assisted evaporation.

Element	Microwave evaporation	Certified value
Ag	1.53 ± 0.04	1.68 ± 0.15
As	13.8 ± 2.2	14.0 ± 1.2
Cd	4.13 ± 0.24	4.15 ± 0.38
Co	0.49 ± 0.02	0.57 ± 0.11
Cr	1.76 ± 0.03	1.43 ± 0.46
Hg	0.063 ± 0.033	0.0642 ± 0.0067
Mn	11.5 ± 0.5	12.3 ± 1.5
Ni	2.29 ± 1.02	2.25 ± 0.44
Pb	0.38 ± 0.07	0.371 ± 0.014
V	4.59 ± 0.27	4.68 ± 0.15

Concentration of analytes (µg/g) in SRM 1566A (Oyster Tissue) following the microwave-assisted evaporation of the digestate compared with the certified total concentrations (uncertainties are expressed as 95% confidence intervals, with n ≥ 3)

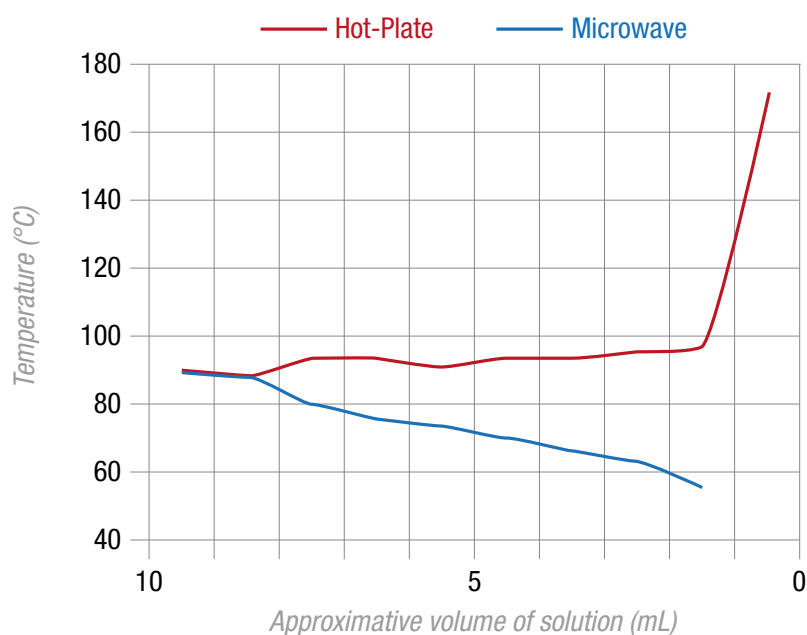

Temperature of solution as volume decreased during microwave-assisted and hot plate evaporation. The final point in the hot plate temperature profile is that of the beaker bottom at dryness.

MMR-15

MICROWAVE MODULAR ROTOR

Fast sample drying
Fast solution concentration
No contamination
Full volatile recovery
US EPA 3052 compliance
Full safety



From digestion to evaporation

HELPING CHEMIST

Milestone has been active since 1988 in the field of microwave sample preparation.

With over 20000 instruments installed worldwide, we are the acknowledged industry leader in microwave technology.

Milestone vision is to help chemists by providing the most technologically advanced instrumentation for research and quality control.

Our products offer a wide range of applications, such as microwave acid digestion, solvent extraction, synthesis and ashing.

Furthermore we create products for acid purification and direct mercury determination in solid, liquid and gas samples.

We offer our customers the highest level of application support, building up over the years a relationship based on trust and commitment.

MILESTONE



H E L P I N G
C H E M I S T S

**UNI EN ISO 9001: 2008
CERTIFIED**

MILESTONE Srl - Via Fatebenefratelli, 1/5 - 24010 Sorisole (BG) - Italy
Tel: +39 035 573857 - Fax: +39 035 575498
www.milestone srl.com - email: analytical@milestonesrl.com

MILESTONE INC. - 25 Controls Drive - Shelton, CT 06484 - USA
Tel: (203) 925-4240 - Toll-free: (866) 995-5100 - Fax: (203) 925-4241
www.milestonesci.com - email: mwave@milestonesci.com

MILESTONE GENERAL K.K. - KSP, 3-2-1, Sakado - Takatsu-Ku,
Kawasaki 213-0012 - Japan - Tel: +81 (0)44 850 3811 - Fax: +81 (0)44 819 3036
www.milestone-general.com - email: info@milestone-general.com

MLS GmbH - Auenweg 37 D-88299 Leutkirch im Allgau - Germany
Tel: +49 (0)7561 9818-0 - Fax: +49 (0)7561 9818-12
www.mls-mikrowellen.de - email: mws@mls-mikrowellen.de