



**CLAIRE® NEO – SAFETY CABINET**  
Experience the new flexibility

**berner**

berner

## MAXIMUM SAFETY AND FLEXIBILITY – INTO THE FUTURE WITHOUT COMPROMISE

“We research, develop, manufacture and distribute the best products and services for personal and product protection“ – that is our ambition. For this reason, premium quality safety cabinets have been our most important core competence for decades. Based on innovative research and development at our site in Germany, we develop trendsetting laboratory equipment – through the pioneering work of our employees and in close dialog with users, our customers and partners.

It is our motivation to offer outstanding technology with the highest level of safety for all the important players in the field of pharmaceutical, medical and biological research and in the production of life-sustaining medicines. This is what gave rise to the claire® neo concept. This revolutionary safety cabinet offers all the possibilities to flexibly adapt to future requirements at any time. An essential and perhaps less obvious basis for this flexibility are the new grid dimensions of the claire® neo. The exact external dimensions in a metric grid of 30 cm allow perfect laboratory planning and seamless integration in coordination with all other components of the laboratory. The concept also allows the rapid adaption of new technical possibilities for a wide range of laboratory applications and the digital integration of the claire® neo into various processes. You can find out more about the innovations and the different possibilities in this brochure.

Maximum energy efficiency and the special flexibility of the concept also represent a significant contribution to sustainability. Our customers can thus meet future challenges in a targeted manner at any time while saving environmental and financial resources. In this way, our claire® neo sets maximum standards in terms of safety, design and flexibility.

Dipl.-Ing. Thomas Hinrichs  
Managing Partner



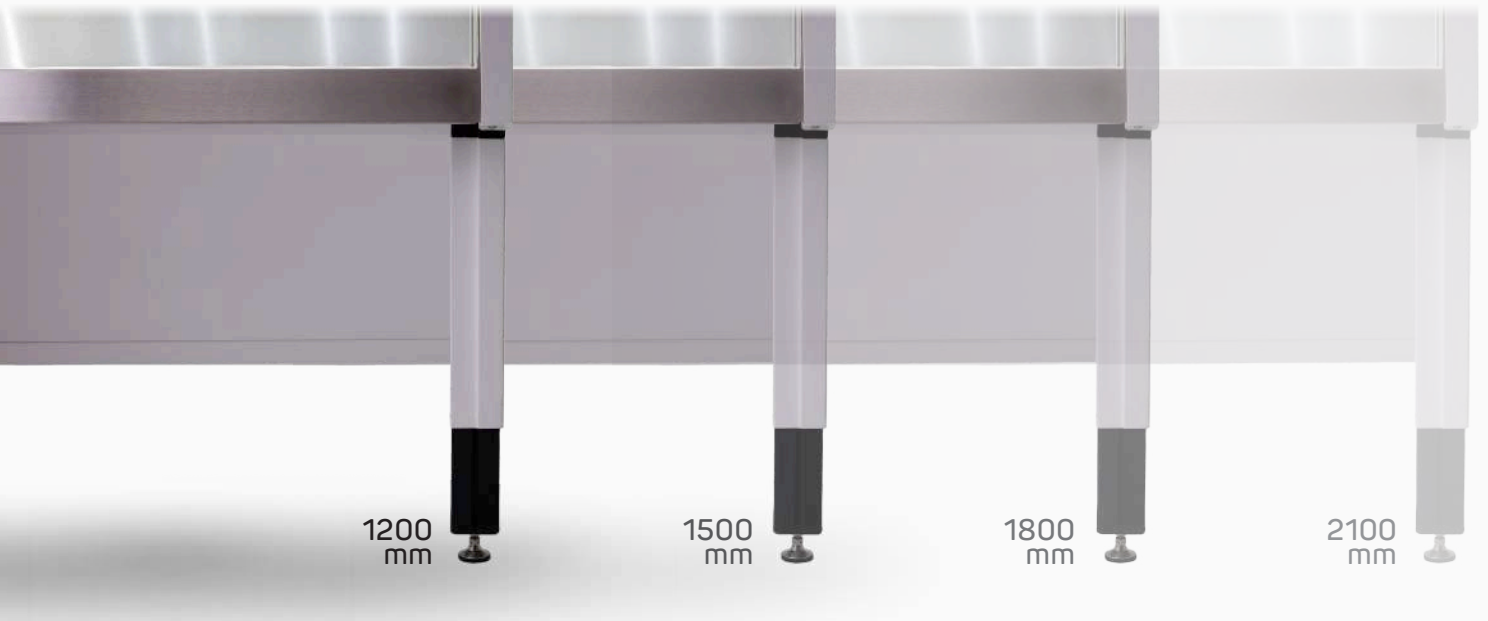

## BEST PLANNING WITH METRIC GRID DIMENSIONS

claire® neo is made for maximum flexibility and modern, digital laboratory planning thanks to its new external dimensions. Unlike previous models on the market, claire® neo is designed for metric grid dimensions in 30 cm increments.

- Exact external dimensions in widths of 1200, 1500, 1800 and 2100 mm, at a standard depth of 800 mm
- Perfect integration into modern laboratory equipment
- Best digital planning and efficient use of space during initial installation
- Maximum flexibility for future laboratory rearrangements

### The metric grid

#### INFO

The dimensions of our claire® pro/pure series or of competitor models are based historically on Anglo-American HEPA filter dimensions in foot increments (1 foot = 30.4 cm). This results in fractional, outer dimensions for these models; a claire® pro 130, for example, has a width of 1352 mm and a depth of 815 mm. In contrast, claire® neo fits perfectly into a metric grid of 30 cm increments.



## FLEXIBILITY FOR THE FUTURE

claire® neo is ready for new tasks and grows with your demands. To be optimally prepared for future uses and laboratory processes, the design of the claire® neo is tailored to maximum flexibility. Many adaptations are therefore not only possible at the time of the initial order but can also be carried out subsequently and on site by our highly qualified service team or even by the users themselves. In this way initial investment costs can also be significantly reduced.

- Extensive portfolio of flexible worktops in various formats, made of different materials or with integrated functions
- Easy on-site installation of 22-inch monitor into the back wall
- Can be retrofitted with various interfaces for data transfer and power supply or with media connections (gases, liquids...)
- Simple on-site conversion from 2-filter to 3-filter system

### 2- and 3-filter system

INFO

As a special product highlight, the claire® neo offers for the first time the possibility to convert the safety cabinet from a 2-filter to a 3-filter model. Due to the innovative airflow architecture of the claire® neo, the third HEPA filter stage can also be easily installed at a later stage. This provides additional safety and is useful or even necessary for working with cytostatics or hazardous biomaterials.



## HIGHEST COMFORT THROUGH INNOVATIVE CONTROLS

The control of the claire® neo is characterized by maximum user-friendliness. This is achieved by a newly developed user interface with intuitive menu navigation that can be optimally operated via the high-end display and the precise touch control.

- Energy-saving Dark Mode
- Swipe gesture functions, can also be easily controlled with gloves
- Individual assignment of 15 function keys (via drag-and-drop)
- Login via codes or RFID chip and easy to configure user profiles
- Interactive error messages
- Touchless switching on via foot sensor
- Customizable cleaning monitoring system

### Additional options

INFO

Further customer-specific options can be easily realized in dialog with our customers and implemented as a function. This ensures maximum flexibility and efficiency - without compromise.

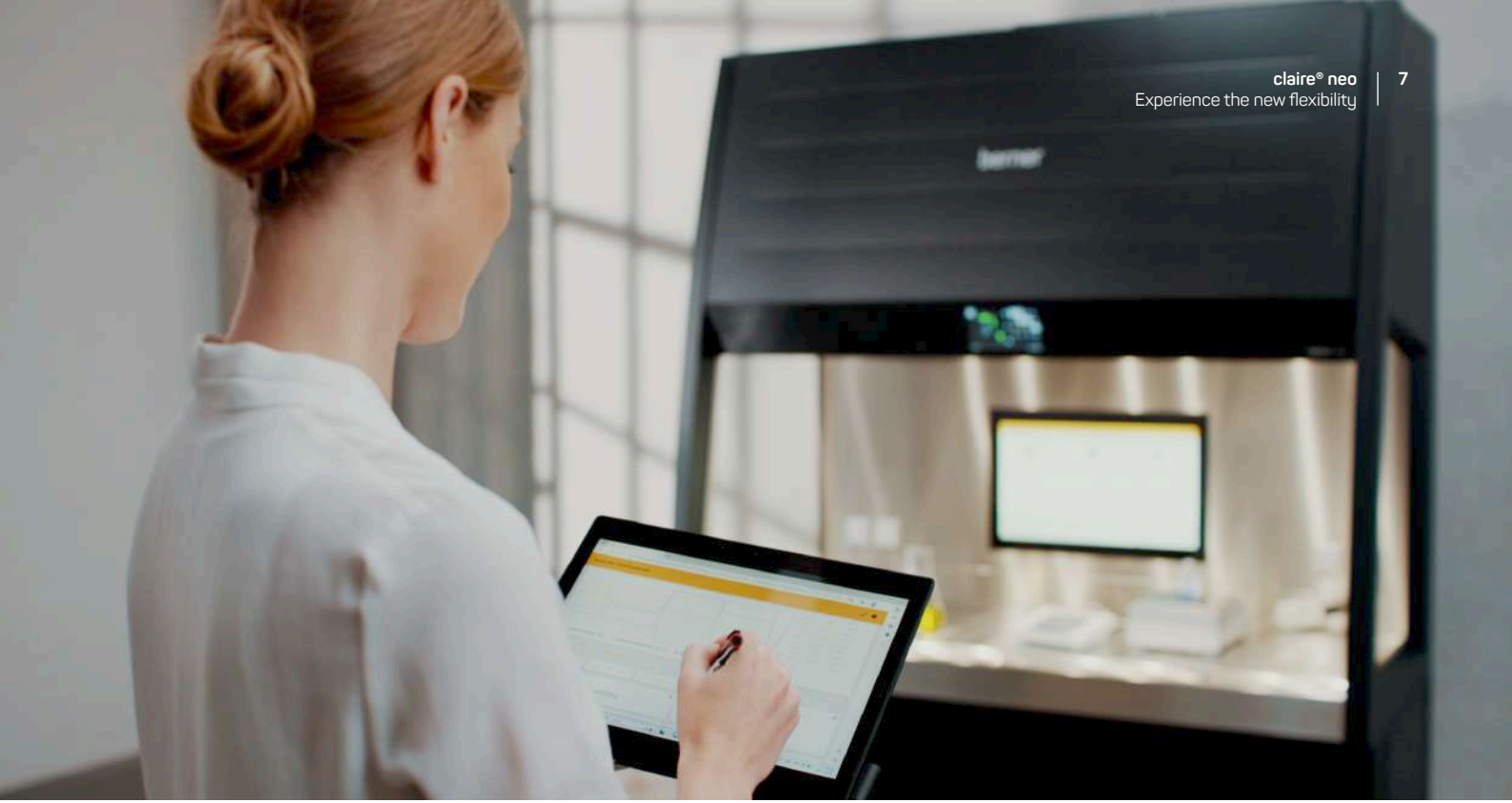

## DIGITALIZATION AND DATA TRANSFER

The Open Platform Communication Unified Architecture (OPC-UA) is a modern solution for universal communication between technical devices and is of great importance in the digitalized and networked production. Our claire® neo allows communication with other laboratory devices and monitoring equipment via an optional and newly developed OPC-UA interface. This interface enables the monitoring of a wide variety of operating data, all logins and alarms of the claire® neo.

- Integration into laboratory monitoring and clean room control systems
- Monitoring of a wide range of operating data
- Recording of all logins and errors
- Communication with other laboratory devices
- Preparation for remote diagnosis and maintenance

### Digital Integration

#### INFO

Digitalization is one of the most important topics in industry and therefore also in the laboratory world and cleanroom technology. claire® neo offers many options for digital integration into existing or future laboratory environments. This is possible due to the flexibly expandable control software from Berner and the variable customization of the OPC-UA interface to meet specific requirements.



## OPTIMAL FUNCTIONALITY

The unique worktop concept offers countless possibilities for the flexible use of claire® neo. In addition to standard stainless steel worktops, an extensive portfolio is available in other designs, including functionalized worktops. Thanks to the universal design of the work surface, all worktops can be interchanged and combined in many ways between all claire® neo models, allowing to flexibly adapt to the specific requirements of laboratory activities.

- New worktop design without ventilation slots for easy cleaning and 12% more work surface
- Sets of segments with widths of 244 mm and 300 mm
- Worktops also available in other sizes (600 mm, 900 mm, ...)
- Enhanced worktops for weighing
- White safety glass worktops for extra bright work environment

The functionalized worktops are designed for ultimate flexibility. Thanks to their unique flush integration, the functions can be used safely without restricting the available work surface and can be arranged as desired:

- Flush and liquid-tight integration for easy cleaning
- Usable as a regular work surface when switched off
- Power supply and data transfer via plug-and-play function below the work surface
- Activation via touch display
- Easy installation and removal by the user
- Flexible arrangement of the worktops

#### EXAMPLES OF AVAILABLE FUNCTIONS:



Tempering function



Keyboard



Magnetic stirrer



LED backlight



## **ENERGY-EFFICIENT AND RESOURCE-SAVING - CONSEQUENTLY SUSTAINABLE**

Operating costs of the claire® neo are very low, due to optimized air flow as well as high-quality and energy-saving components such as new EC fans, LED lighting throughout and the new touch display in Dark Mode. In addition, the claire® neo offers a particularly energy-efficient ECO mode, which can be further enhanced by the ESM (Energy Save Mode) function – a special option to further reduce energy consumption by adjusting the brightness of the lighting and display. Demand-based control of energy consumption is also possible by automatically switching the safety cabinet on and off via the Auto-On/Off function.

- Consistent use of high-quality, energy-saving components
- Intelligent fan control and optimized airflow
- Dimmable LED lighting
- State-of-the-art sensor technology for Auto-On/Off function
- Choice of ECO mode as tested basic setting instead of GMP mode
- Combination of ECO mode with ESM (Energy Save Mode) function for further energy reduction
- Better energy efficiency – power consumption reduced by between 9% and 17% compared to claire® pro\*

\* per metre of working width, claire® neo B-3-150 compared to claire® pro B-3-130 (GMP/ECO mode)

Our claire® neo is consistently designed for uncompromising adaptation and expansion to our customers' current and future fields of application. We consider this main feature of our claire® neo series as our special and innovative contribution to a mindful use of our planet's resources.

The overall high level of sustainability combined with proven performance and safety is achieved in the claire® neo series through many design elements.

- Simplest integration into laboratory design, even in rearrangements, thanks to universal grid dimensions
- Possibility of simple conversion from 2- to 3-filter system
- Particularly easy and selective filter replacement with 3-filter systems
- Premium quality - Made in Germany
- Added value created in Germany to more than 95%
- Use of regional suppliers with short transport distances
- Design of all components for long lifetime with typical lifetime > 15 years (except wear parts)
- Main components made of metal with complete recyclability into the material cycle

## Retrofitting and conversion

### INFO

In terms of resource-saving sustainability the extensive and simple retrofitting and conversion options are a key feature of claire® neo compared to previous concepts.

For example, claire® neo offers the possibility of easily converting a 2-filter system to a 3-filter system. Compared to common practice this not only eliminates the need to invest into a completely new safety cabinet. At the same time almost all components of the 2-filter system can be used directly in new applications with extended requirements. The concept of construction in metric grid dimensions also avoids resource- and investment-intensive replacements. In combination with modern, digital planning, future laboratory rearrangements can be easily realized using the existing equipment.

## PROVEN PREMIUM QUALITY

claire® neo combines new flexibility with proven premium quality. In addition to the numerous new functions, established product features such as the Movement-Measurement-System or the Shield-Design remain unchanged.

flexible



## Color

INFO

The powder-coated outer surfaces of the claire® neo come in white color as standard. The black color shown in this brochure is available as an option.

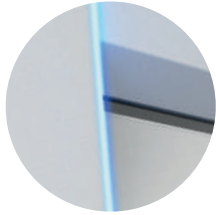

### Innovative LED lighting technology

Apart from the LED lighting of the working space, laterally arranged LED light bands and the illuminated window edge in the view of the user visualise the operating state or alarms and guarantee the highest security.



### Movement-Measurement-System

Detection system for movement of persons and the resulting perturbations near the work opening, which creates clear warnings and raises awareness of the laboratory personnel.



### Protection shield

The multiple award-winning „Shield Design“ testifies the high design quality that combines innovation in form and function in an exemplary manner.



### Ergonomics

Particularly quiet and bright operating conditions, individually adjustable work surface height and the user-friendly V-shaped air intake allow high ergonomics even when working for extended periods of time. In addition, the claire® neo offers optimum legroom even with 3-filter systems thanks to the particularly compact design of the first main filter.



### Energy-saving Auto-On/Off function

The optional Auto-On/Off function detects the absence of the user – the safety cabinet is shut down in a controlled manner. The modern sensor system detects the approach of the user and initiates the start of the claire® neo without contact – ventilation and lighting are switched on and the front window is opened again.

future-oriented



## QUALITY, RELIABILITY AND INNOVATION TECHNOLOGY MADE IN GERMANY

Developing trendsetting solutions and thereby setting standards for safety in the laboratory – this is our guiding principle and daily motivation. For us, research forms the base for innovations – that is why we develop innovative solutions in numerous research projects and in cooperation with universities that make working in the laboratory even safer and easier.

claire® neo combines innovative technology with proven premium quality and, thanks to the sum of its components and properties,

sets completely new standards for safety cabinets in terms of performance, function and design.

Thanks to established tests in our own laboratory according to DIN EN 12469, DIN 12980 or NSF 49, prototypes and customised special designs are tested in our own R&D laboratory. The interplay of a wide range of options and customized one-off solutions stands for individual applications and maximum safety - Made in Germany.

# TECHNICAL INFORMATION

## claire® neo

### General data

Device	Laboratory device
Type of device	Cytostatic safety cabinet or microbiological safety cabinet
Type of construction	DIN EN 12469; NSF 49; DIN 12980
Marking	CE
Quality management system	DIN EN ISO 9001
Certificate	TÜV GS (being reviewed)

### General technical data

Nominal illuminance	0 – 1,100 lux
Vibration (RMS) on worktops	≤ 5 µm
Sound pressure level conforming to ISO 11201	< 60 dB(A)

### Material specific data

Material workspace	1.5 mm stainless steel „V2A“, material no.: 1.4301
Surface finish workspace	400 grit fine finish, mean roughness index Ra ≈ 1.6 µm
Material casing	Powder-coated 1.5 mm strong Zincor-steel sheet, material no.: 1.0330
Powder coating colour	White RAL 9003 matt Black RAL 9005 matt
Front-, side and back panel	Multi-layer safety glass with UV-light absorbing interlayer

### Electrical data

Rated voltage/ Rated frequency	230 V AC / 50/60 Hz
Power consumption ECO/ GMP [1] (here: B-3-150)	180/365 W

### Mechanical data

Outer width	1200, 1500, 1800 and 2100 mm
Height	1967 – 2317 mm
Depth	800 mm
Clearance dimensions (HxD)	1947 x 800 mm
Worktop height	650 – 1000 mm (in 8 steps)

### Ventilation data

Filter classes (with main-, recirculation & exhaust filter)	Min. H14 (Filtration rate: E ≥ 99,995%), in acc. DIN EN 1822-1 [2]
---	--

Cleanroom class in workspace	EC-GMP-Guidelines: A; DIN EN ISO 14644-1: ISO-class 5
------------------------------	--

[1] Without extra consumer

[2] Integral degree of filtration as minimum filtration efficiency for max. penetration, with particles of the Most Penetrating Particle Size (MPPS)

Several additional options are illustrated in this brochure.

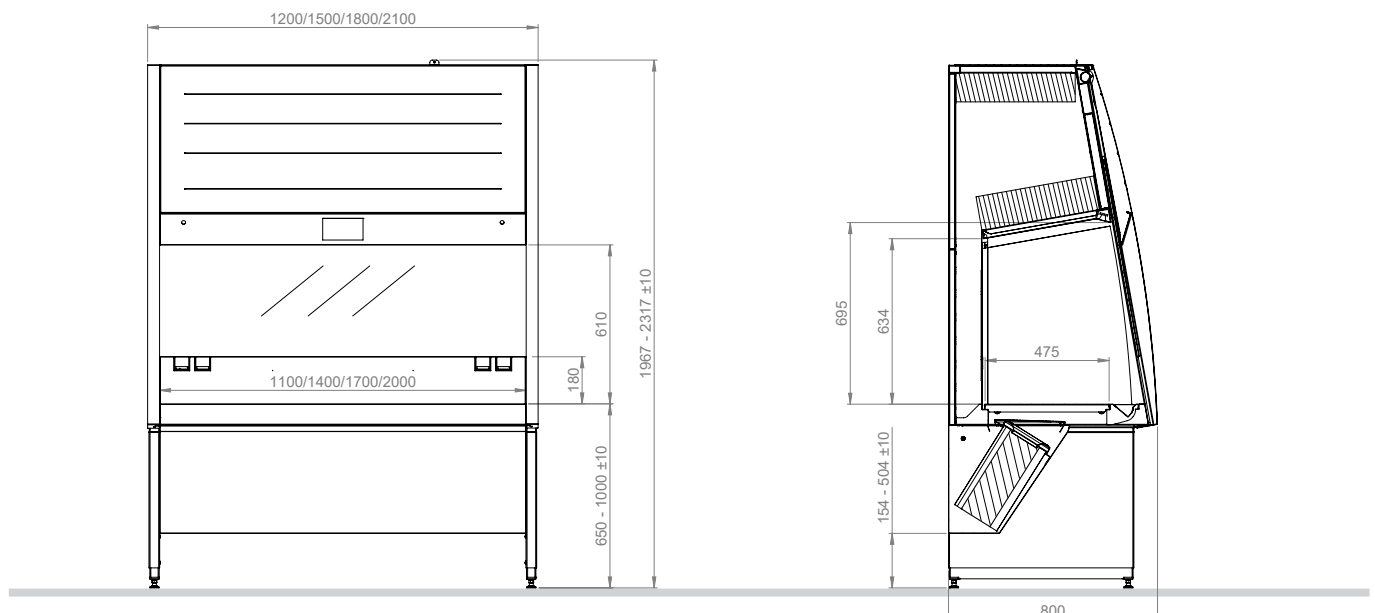



Awards received for a design model of claire® pro

V1-23/12 EN

Berner International GmbH  
Werner-von-Siemens-Str. 19  
25337 Elmshorn  
Germany

Tel +49 4121 4356 - 0  
Fax +49 4121 4356 - 20  
Email [info@berner-safety.de](mailto:info@berner-safety.de)

[www.berner-safety.de](http://www.berner-safety.de)



Currently being examined.